

" EGGBEATER " ANTENNA VHF/UHF ~ PART 2

ON6WG / F5VIF

Summary

Note : In Part 1, Fig 1 shows a maximum gain of 6.45 dBi. Several design attempts were made using slightly different configurations (i.e. reflector to radiator distance, radius of the reflector, etc...). It was not possible to improve the gain above this value.

In Part 1, three particular satellites were chosen for the receiving tests. They were mainly chosen because of their similar orbits, close to 800 km, and then for their transmission system, antennas and polarization system. The comparison table (Part 1 – page 5 'Levels of received signals') was computed after twenty passes for each of them and gives an average value of received signals.

Two properties of the $\frac{1}{4}$ wavelength line were tested and put into practice: impedance matching and 90 degree phasing to obtain circular polarization. In this design we make use of the same two properties of the coaxial line.

It was also shown how the reflector can influence the radiation field pattern giving to this design a gain of 6.5 dBi. at high elevation angles (between 60 and 90 degrees.).

This design was created to obtain signal levels as high as possible in order to use high speed digital communication satellites. The goal was also to use a simple antenna without any rotator.

As strong signals are needed for this purpose, low satellite passes with low signals were not taken into consideration. The result is a good design for elevations over 35 degrees.

Here in Part 2, we are examining how to further improve the performance of this design.

Introduction

In « Part 1 » we saw a '2 dimensional' radiation field pattern. Here I am using a '3-D' radiation field pattern of this circularly polarized antenna.

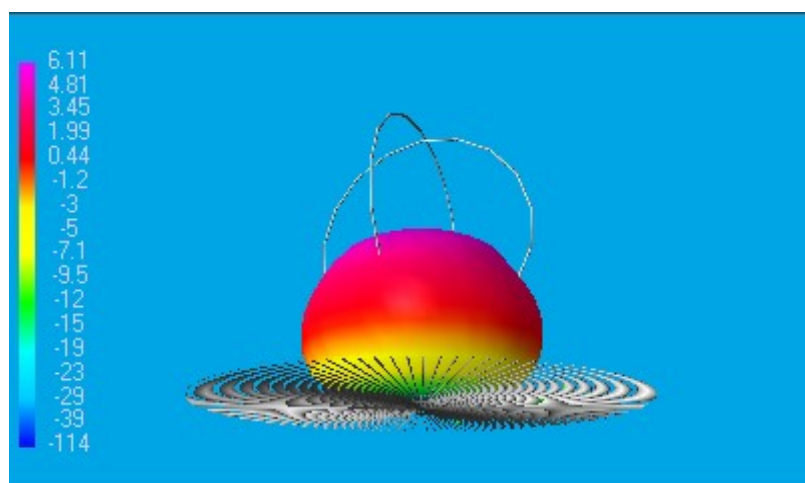

Fig 8

3-D development shows a good view of the radiation field pattern as well as the gain at different elevation levels. The maximum gain, shown here as purple in colour, covers an elevation angle from 60 to 90 degrees.

The ability to reverse the polarization (RHCP to LHCP) will greatly improve the antenna performance. I decided to connect a coax switching relay at points C and D, (see Part 1, fig. 7), inside the tube used to support the antenna. If the relay can not be fitted here, we can use the properties of the $\frac{1}{2}$ wavelength coax lines, to fit it lower down, where there is more room.

Explanation : when a section of coax line is equal to or is an even multiple of a $\frac{1}{2}$ wavelength, the impedance measured at the beginning of it will be reproduced at the end of it. We can use any type of coaxial cable (RG-155, RG-58 or RG-62) to make a link between the coax relay switch and the antenna. So each loop can be coupled to the relay by a $\frac{1}{2}$ wave, or 1-wavelength or $1 \frac{1}{2}$ wavelengths of coax; any half wave multiple in fact. To calculate the electrical length of this $\frac{1}{2}$ wavelength line, the velocity factor must be taken into account.

Electrical length = measured length x velocity factor.

If the lines are correctly cut, an SWR meter placed in the feeder will not show any difference in its measurement, with or without the $\frac{1}{2}$ wavelength lines in the circuit.

Schematic

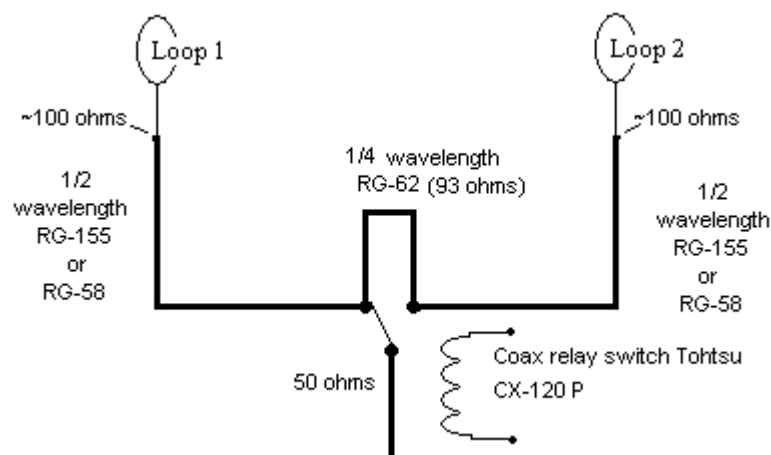

Fig 9

For information, here are the calculated lengths for the $\frac{1}{2}$ wavelength RG-58 coaxial lines (velocity factor 0.66) used in the prototype antennas.

145 MHz : 68.5 cm

435 MHz : 22.8 cm

The $\frac{1}{4}$ wavelength line can be connected on the coax relay switch. Then the $\frac{1}{2}$ wavelength lines can be soldered to the coax relay, and all the lines folded over, (as shown in Fig 11), so as to slide in side the tube supporting the antenna.

Choosing a coax relay switch

Manufactures of 50-Ohm coax switching relays are not too numerous. After some searches, it seemed to me that the TOHTSU CX120P coax relay was the best compromise for this purpose. It is small enough to enter in a 2 inches diam. tube. At a frequency of 500 MHz, it can be used with an input power of 150 watts and the isolation is still good (40 dB). The insertion loss is 0.2 dB. Maxi. VSWR is 1.3.



Fig 10

Fig 10 shows the coax relay used on the antenna. The CX120P model is specially made to be used on printed circuit boards. This model is the more convenient because any size of coax cable can be connected to it. The CX120A model can also be used but it accepts only one size of coax cable.

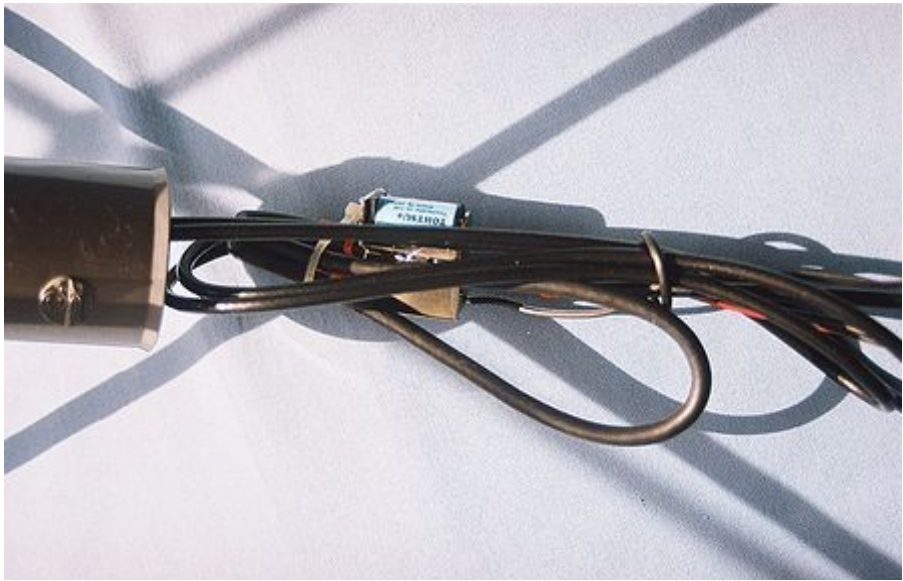

Fig 11

Fig 11 shows coax switching relay, folded $\frac{1}{4}$ and $\frac{1}{2}$ wavelength lines and fittings. A part of the tube supporting the antenna is seen on the left side of the picture. The shadow is produced by the antenna itself.

SWR measurement with CX120P coax switching relay installed :

<u>UHF</u> :	Freq. MHz	430	432	435	436	437	438	440
	SWR	1.5	1.4	1.2	1.2	1.3	1.5	1.5

<u>VHF</u> :	Freq. MHz	144.....146
	SWR	1.3

Performance

As soon as the polarization of a received signal is inverted, the level of the signal can be maintained by interchanging the polarization of the antenna. It can be also useful sometimes when transmitting to the satellite.

Proximity of the VHF and UHF antennas

When using J-mode, VHF and UHF antennas are often close to each other. As these two bands are used simultaneously, an interference problem can appear on the UHF receiver. It can be caused by the third harmonic when transmitting on VHF. To solve this problem the third harmonic must be removed at the transmitter with a band-pass filter. Separating with some distance the VHF and UHF antennas is also another way to solve it. If, for some reason, it is not possible to separate the antennas with enough distance, one can add a duplexer 144/430 MHz in the feeder line of the UHF receiver. The 144 MHz connector of the duplexer must be left unconnected.

Appendix I

Polarization change and satellite attitude on a circular orbit : A special case.

The attitude of a satellite is its orientation related to one or several co-ordinate points. These co-ordinate points can be either the center of the Earth, the Earth, the Sun etc... Attitude control systems are placed on board a satellite to give it orientation. Attitude control can be used for orientation of antennas, solar panels, camera or various experiments.

However its main use is to stabilize the satellite. As soon as it is stabilized, other control systems can be used to stabilize other elements like, for example, the internal temperature.

The simplest attitude control system is made with magnet rods. These magnet rods will fall into line with the Earth magnetic field, just like the needle of a compass.

Figure 12 represents the attitude of a satellite equipped with this kind of system passing along its course on a circular orbit around the earth. Notice the turning over of the satellite when passing over the Poles.

The magnetic terrestrial field is shown white in colour. The satellite orbit is shown in red.

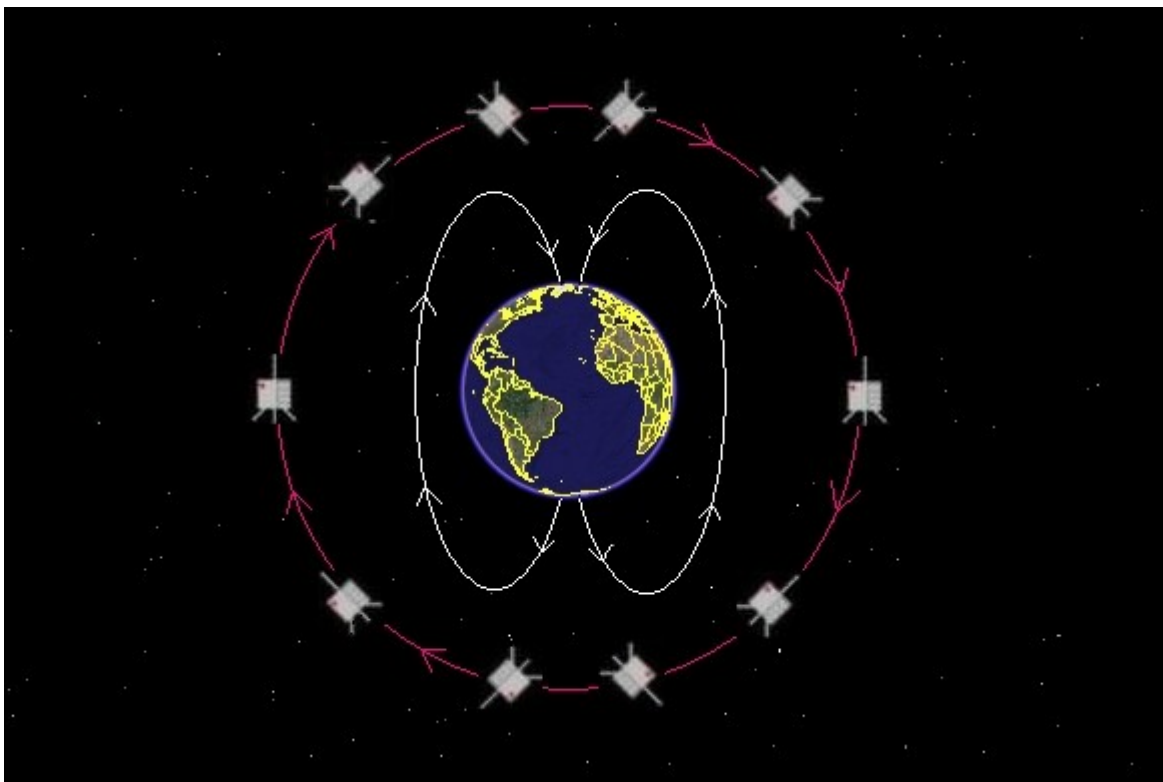

Fig 12

Now moving away from the Poles, what is seen by the antenna located on the earth and tracking this satellite ?

The answer is illustrated on Fig 13. Assuming the approaching satellite is using a RHCP turnstile antenna, the receiving antenna on earth sees a RHCP signal. When passing the Zenith (perigee) of its orbit relative to the the receiving station, the receiving antenna on earth sees the other side of the satellite's turnstile antenna and consequently a LHCP signal.

So, polarization change is not only due to propagation but is in some cases also depending of the attitude of the satellite itself.

In conclusion, we can see the value of having reverse polarization available, on a satellite receiving antenna.

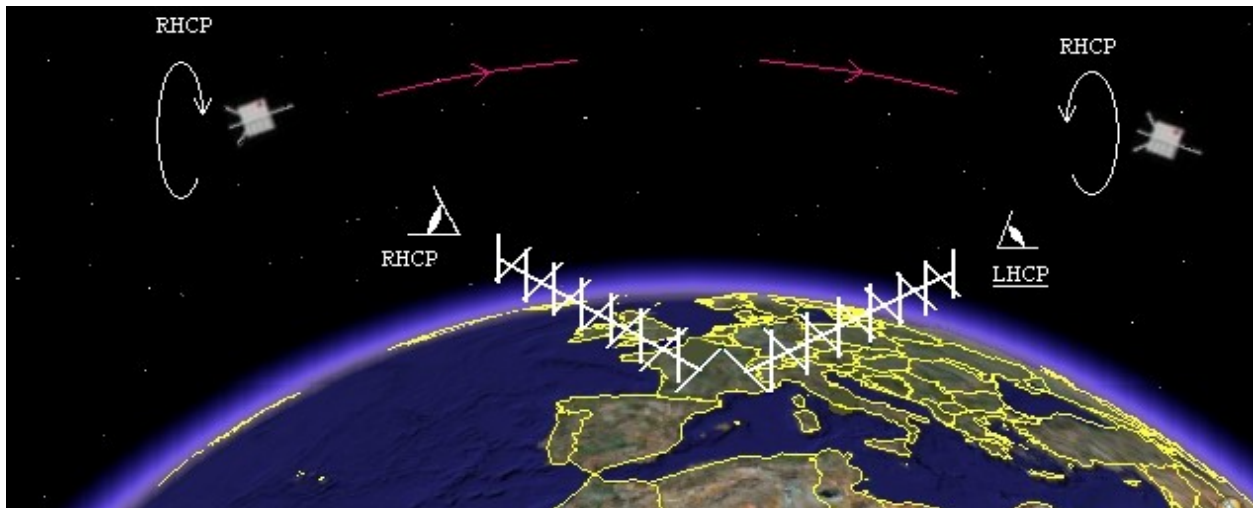

RHCP : Right Hand Circular Polarization

LHCP : Left Hand Circular Polarization

Fig 13

Appendix II

Click on the links below

To see technical data of CX120P coax relay switch :

_____ <http://www.tohtsu.com/> _____

To find a place to buy the coax relay CX120P :

_____ <http://www.maes-electr.be/> _____

Then click on 'Producten' , ' Toebehoren' , ' Tohtsu '

Special thanks to Nigel G4DCQ, for his comments, suggestions and improvements to the English text.

French translation of this article

Traduction française de cet article .. <http://www.on7wr.be/Gigazette/ON6WG/eggbeater2.pdf>

ON6WG / F5VIF Website <http://pagesperso-orange.fr/on6wg/>

To contact the author : _____ <mailto:f5vif@amsat.org> _____

ON6WG/F5VIF PDF File Use Policy

PDF files may be copied or distributed for any non commercial use without prior permission. If a part of the document (text, image, picture, schematic) is used separately, the user agrees to indicate the source of it. A URL must be provided, either to the home page of the ON6WG/F5VIF website or to the page providing the link to the part of the document. The user agrees also to use a credit line in connection with the part of the document, unless the part of the document already contains this information. The credit line should be "Courtesy ON6WG/F5VIF".
Read also the "Terms of Use for the ON6WG/F5VIF Website".