

# ~ PushButtonRadioTune ~

## Hardware Interface

ON6WG / F5VIF

### Introduction

This section is a supplement to the User's Manual of PushButtonRadioTune (PbRadioTune). Just a few parts are needed to build the interface to control the radios. A small PCB, eight LED, three PhotoMOS relays, fourteen resistors, one DB-25 (male) connector and a small box are the main elements of the list. The diagram detailing the parts is shown on page 2.

PhotoMOS relays were chosen mainly as they are very similar to optoisolators but more versatile. First of all they work as simple switches (perfect when connected to the UP/DOWN switches). AC or DC loads can be switched (this can be useful for additional channels). The allowable load voltage is also higher than regular optoisolators. The PhotoMOS relay input needs only a few mA of current to drive and turn on a LED inside the device (for more informations about the AQW210EH PhotoMOS relay used in this interface look at the datasheet in the appendix).

On each line connected to the PhotoMOS relays, a LED is added to visualize the pulses as described in the manual. Since the power consumption on the parallel port must remain very low, resistors are calculated to maintain the consumption at a low level.

Note : the interface does not need an external power supply.

### System bloc diagram

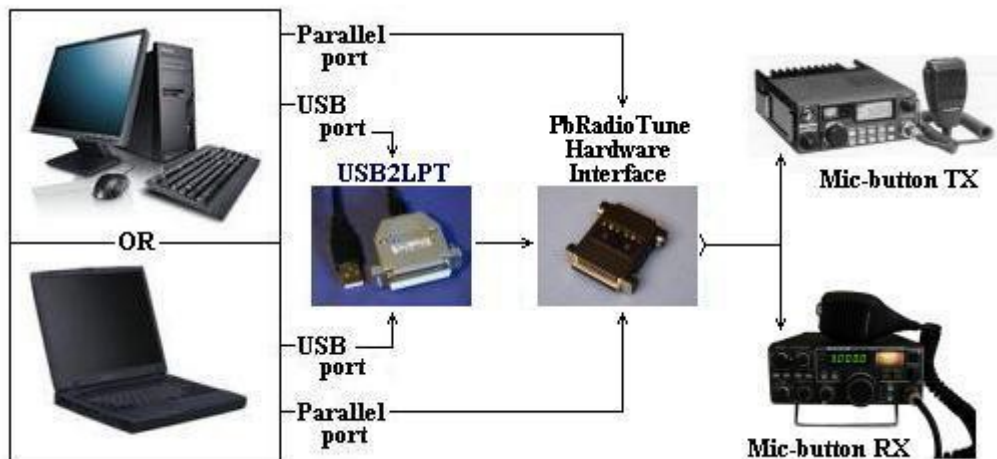

The bloc diagram shows the connections between the devices. Any type of computer can be used (a desktop computer or a small notebook will work). If a parallel port is available, it will be connected directly to the hardware interface. If a USB port is only available, the computer will be connected to the hardware interface via USB2LPT (more informations about the installation of USB2LPT can be found in the article entitled "DOS, IT & Ports" on Page 3 of my web site or click ["here"](#) to reach the article.

DB-25

### PushButtonRadio Tune Hardware Interface

To Parallel Port

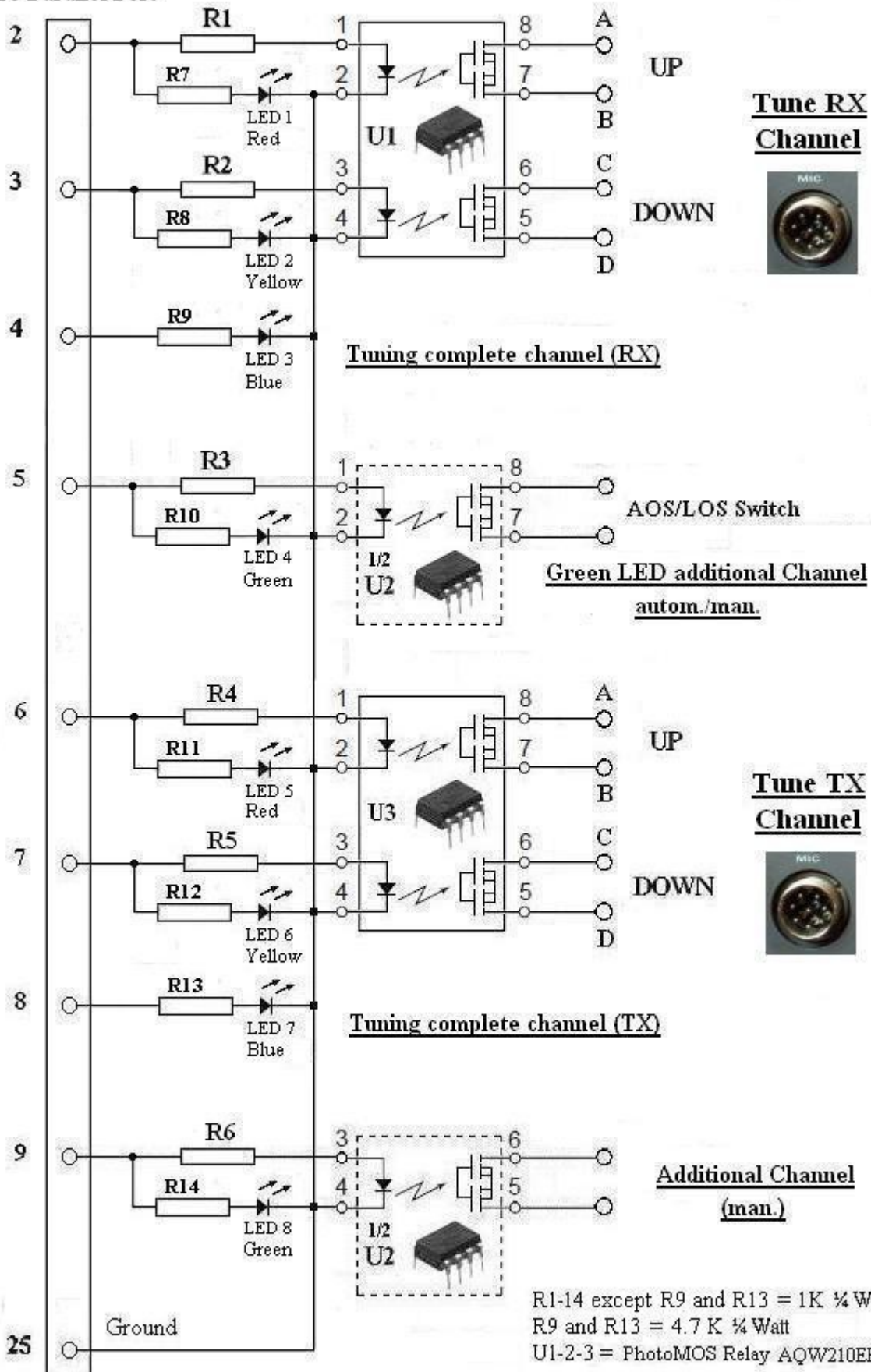

The interface may easily be mounted in a housing adapter DB25 / DB25 as shown in **Fig 1**. Note that the three PhotoMOS relays fit perfectly next to one another in the housing adapter on the female side. The LEDs series resistances were calculated for a LED standard model (except for the blue LEDs). The resistance may vary from 1K to 3.9K depending of the LED model, the consumption or the brightness needed.

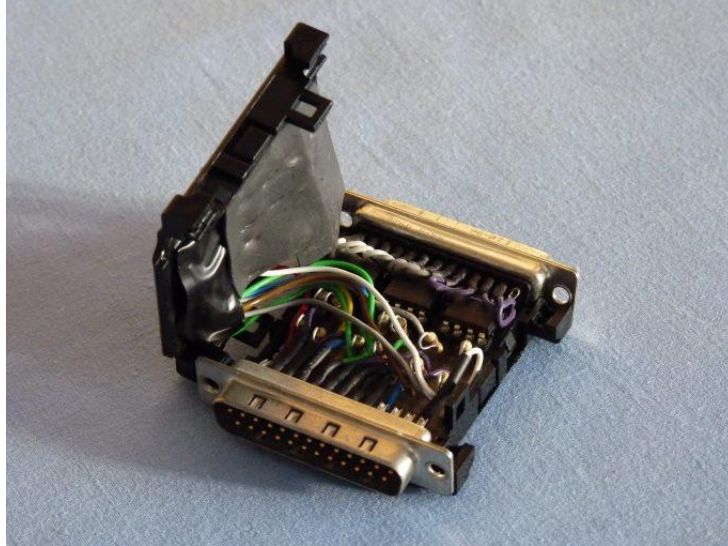

**Fig 1**

The interface housing closed and ready to use is shown in **Fig 2**. The blue LEDs indicating that the RX tuning or the TX tuning is complete are located in front of their respective channel. We see immediately which channel is in operation. The green LEDs show the operation of the two independent additional channels.

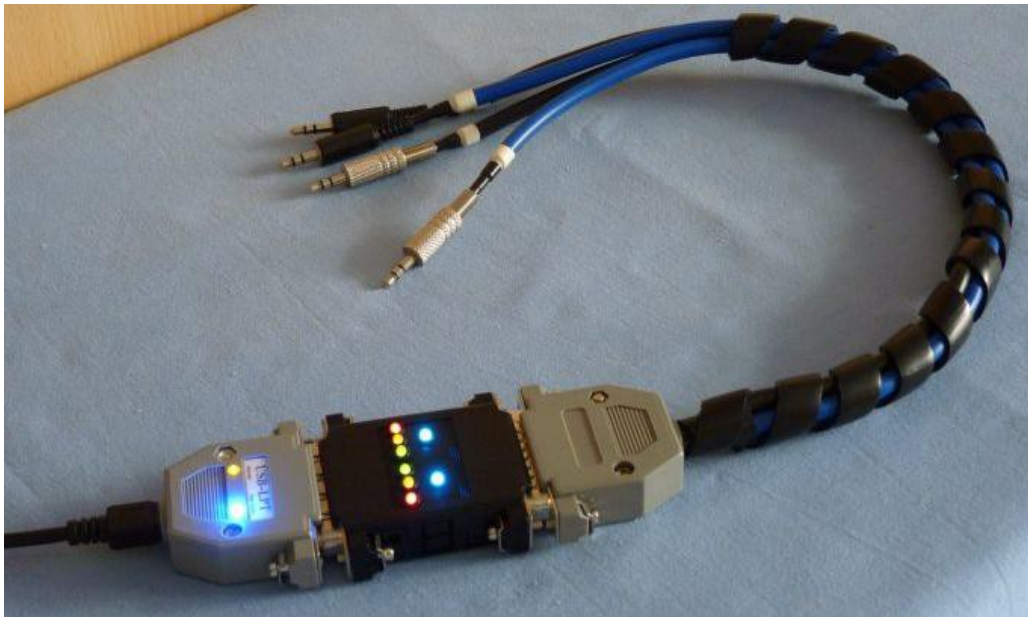

**Fig 2**

Note : As the LEDs for visual control signals are all optional ( the result is shown on the displays of the radios ), the interface can be achieved by keeping only the three PhotoMOS relays and their series resistances. Building the interface is then simplified.

## The interface in pictures

**Fig 3** and **Fig 4** below show the necessary hardware between the computer and the radios ( USB2LPT - PbRadioTune interface - Connection cable to the UP/DOWN buttons ).



**Fig 3**

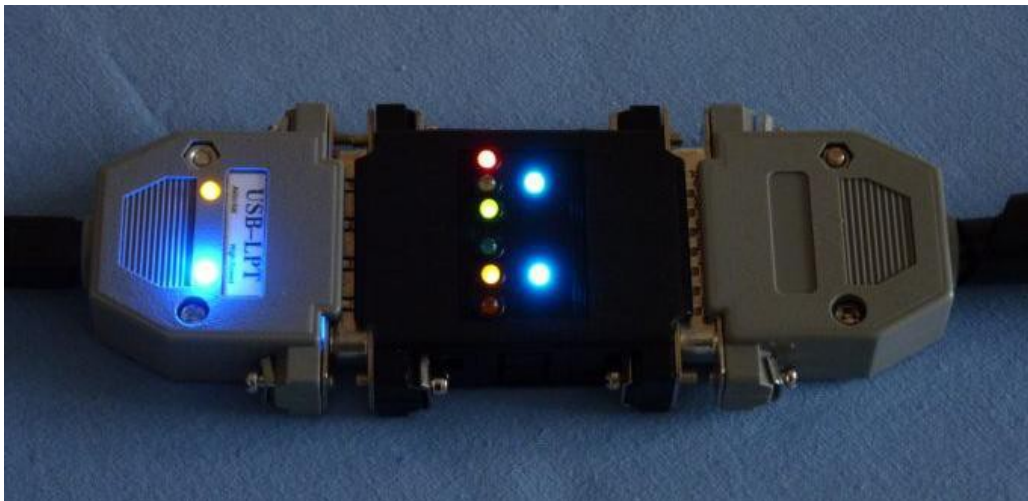

**Fig 4**

In **Fig 3** the interface is tested using the program *ON6WG/LPT TEST*. **Fig 4** shows the interface controlled from **PbRadioTune** during the pass of a satellite. The RX and TX channels were activated (blue LEDs). At the very instant the picture is taken a pulse is transmitted to the RX channel (red LED). By coincidence a pulse is transmitted at the same moment to the TX channel (yellow LED). The additional channel showing that the satellite is within reach (AOS) was automatically activated (green LED).

**Fig 5** and **Fig 6** show the interface in operation connected to a small laptop computer. They also show the joint use of **PbRadioTune** with **Orbitron**.

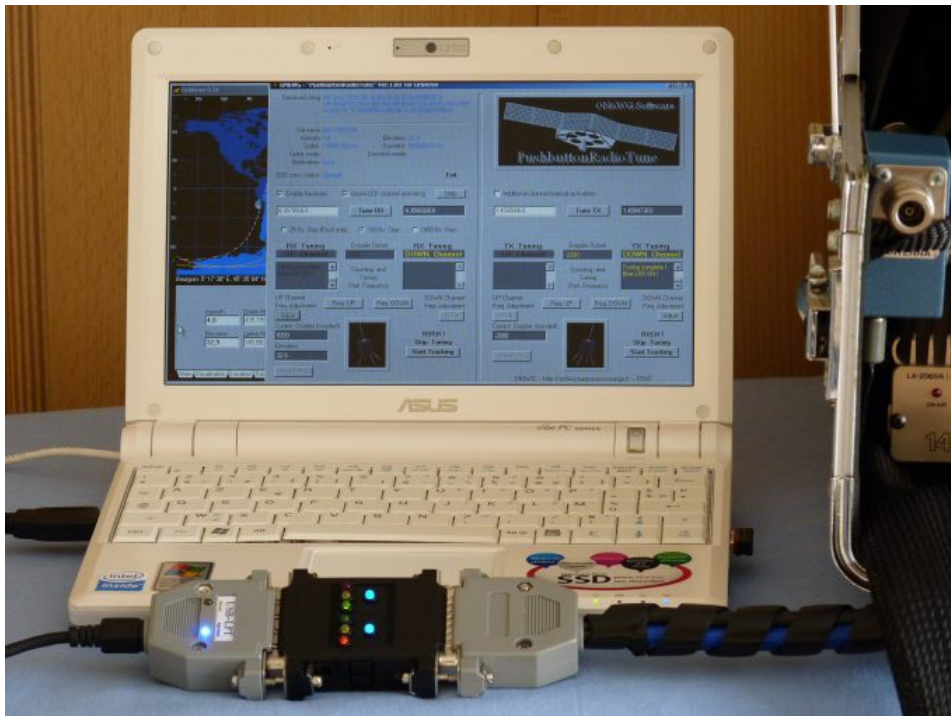

**Fig 5**



**Fig 6**

On this small laptop model and for illustration purposes also **PbRadioTune** takes the size of the screen. However it works perfectly when minimized or in the background behind **Orbitron** as shown in **Fig 6**.

**Fig 7** is an overall picture of the digital equipment in operation controlling a VHF/UHF station during the pass of a satellite.

Note : On the transceiver used as TX the PTT do not need to be switched in continuous transmit mode so that the TX frequency is corrected (the transceiver is working in simplex mode so the transmit frequency and receive frequency are equal).



**Fig 7**



**Fig 8**

**Fig 8** shows the connections to the UP/DOWN buttons on the microphones connectors. The connectors for the two additional channels are also visible.

## Appendix and bibliography

### PhotoMOS relay AQW210EH datasheet

Click on the link below to see the datasheet

Web link

<https://na.industrial.panasonic.com/products/relays-contactors/semiconductor-relays/photomos-relays/series/photomos-ge-2-form/1905/model/AQW210EH>

PhotoMos Relays AQW210EH can be obtained from

**Mouser Electronics Inc.**

( Mouser Ref. 769-AQW210EH ) heading “Panasonic Solid State Relays”.

Click on the link below and first choose your country :

Web link

<http://www2.mouser.com/localsites/>

### USB2LPT Converter

Web link

<https://www-user.tu-chemnitz.de/~heha/basteln/PC/USB2LPT/ul-17.en.htm>

### PushButtonRadioTune Software

Web link

<http://on6wg.pagesperso-orange.fr/Page%2010.html>

### ON6WG/LPT TEST Software

Web link

<http://on6wg.pagesperso-orange.fr/Page%2012.html>

\* \* \*

**Pictures and schematics :** *by the author ON6WG / F5VIF*

**ON6WG / F5VIF Web site :** ..... <http://on6wg.pagesperso-orange.fr/>

**73' s** ..... [mailto: f5vif@amsat.org](mailto:f5vif@amsat.org)

### ON6WG/F5VIF PDF File Use Policy

PDF files may be copied or distributed for any non commercial use without prior permission. If a part of the document (text, image, picture, schematic) is used separately, the user agrees to indicate the source of it. A URL must be provided, either to the home page of the ON6WG/F5VIF website or to the page providing the link to the part of the document. The user agrees also to use a credit line in connection with the part of the document, unless the part of the document already contains this information. The credit line should be "Courtesy ON6WG/F5VIF". Read also the "Terms of Use for the ON6WG/F5VIF Website".